



ELECTRIC DEPARTMENT

**GENERAL SPECIFICATIONS
FOR INSTALLATION
OF UNDERGROUND UTILITIES**

NOTE TO DEVELOPERS

These specifications have been thoughtfully and carefully laid out for your use. Please read over and become familiar with them before beginning your project. These specifications must be followed completely. Please check with your Huntsville Utilities Inspector to be sure that you have the most recent copy of this specification. Should you have any questions concerning this specification, please contact the Huntsville Utilities' Engineering Services Section.

North County

Larry Dixon Office 256.535.1309
 Mobile 256.652.8658
 larry.dixon@hsvutil.org

West County

Trent Hall Office 256.535.1306
 Mobile 256.652.8620
 trent.hall@hsvutil.org

South and East County

Steve Parker office 256.535.1420
 Mobile 256.652.8619
 steve.parker@hsvutil.org

Descriptions of areas are approximate and could change. Call the Engineering Services Office at 256.535.1315 if you are unsure which inspector would be handling your project.



Stacy Cantrell
Engineering Services Manager
Huntsville Utilities

Revised: September, 2013

HUNTSVILLE UTILITIES ELECTRIC DEPARTMENT
GENERAL SPECIFICATIONS
FOR INSTALLATION
OF UNDERGROUND FACILITIES

Table of Contents:

0.0 General.....	2
1.0 Inspections	3
2.0 Conduit	4
3.0 Trench	7
4.0 Marking Tape.....	7
5.0 Fixtures	7
6.0 Vaults and Manholes	9
7.0 Slope Installations.....	9
8.0 Secondary and Metering	9
9.0 Access Roads	10

Appendix A Specification Drawings

0.0 GENERAL

- 0.1 Huntsville Utilities requires the Owner or Developer to be responsible for the proper installation of conduits and fixtures to be used for the installation of Huntsville Utilities' electrical cable, transformers, cabinets, streetlights, and other equipment. Proper installation is detailed in these specifications and is enforced by inspection by a Huntsville Utilities Inspector.
- 0.2 Proper installation includes using approved materials, approved installation methods (with intermediate inspections), and approved locations. Some materials must be provided by Huntsville Utilities and others must be provided by the Contractor). Installation methods must ensure that no damage is done to the facilities during construction and that electrical equipment may be installed in and on these facilities with no problems. Approved locations ensure that the facilities are accessible and maintainable.
- 0.3 These specifications refer to the installation of Huntsville Utilities' facilities for electrical installations. They do not in any way intend to replace the electrical or other requirements of local jurisdiction and further do not pertain to electric wiring beyond Huntsville Utilities' point of service delivery. Any conflicts between this specification and other requirements must be resolved through the Huntsville Utilities Inspector.
- 0.4 Some of the materials to be installed by the Owner/Developer will be supplied by Huntsville Utilities. Materials that are not supplied by Huntsville Utilities, mainly conduit and fittings, are described in these specifications. It is the responsibility of the Owner/Developer to purchase materials meeting these specifications.
- 0.5 A portion of the Aide-To-Construction fee (ATC) must be paid before materials can be released for the job. This amount is determined by the Engineering Aide for the project. Call 535-1315 if you do not have the direct number for your Engineering Aide.
- 0.6 ATC may be paid at 112 Spragins Street.
- 0.7 Once the appropriate portion of ATC has been paid, a Materials Release Form may be issued to allow materials to be picked up at 1145 Jordan Road. The Materials Release Form may be picked up at 112 Spragins Street, and is required when picking up materials.
- 0.8 Huntsville Utilities will assign an Inspector to your project depending on the location. The purpose of the Inspector is to answer questions and perform inspections at key points during construction to ensure that these specifications are followed.
- 0.9 Key points in construction requiring inspections are pointed out in these specifications. Please give your inspector 24 hours advance notice to schedule an inspection.
- 0.10 These specifications are in place to ensure a quality installation of facilities. The result must be a system that can be safely and efficiently operated, and will not require modifications in the near future due to poor installation or workmanship.
- 0.11 Should any questions arise that are not clearly answered by these specifications, the Huntsville Utilities Inspector will determine an appropriate solution.
- 0.12 It is the responsibility of the Contractor to secure any licensing or permitting and to comply with any local ordinances (including, but not limited to, those regarding to ROW)

0.13 DEFINITIONS:

- **Primary Conduit**- conduit to be used for primary cables at 7200kV or more
- **Secondary Conduit** – conduit to be used for service voltage (less than 750V; normally 120/240V in residential areas); this includes street light conduit
- **Service Conduit** – conduit to be used for service voltage – this is the section of conduit that will connect directly to the meterbase on the house. Normally a stub-out will be provided for a future service conduit.
- **Final Grade** – top of curb or, if no curb, top of asphalt
- **Sub-Grade** – level of road when all cuts and fills have been made, blue markers have been placed, and the road bed is ready for base
- **Front of Fixture** - the access side of the fixture – normally will face the ROW
- **Final Inspection** – when the Huntsville Utilities Inspector approves the entire installation and all ATC has been paid; at this point the job is released to Huntsville Utilities operations department to be scheduled for work

1.0 **INSPECTION**

- 1.1 Before starting your project, an on-site job meeting **must** be scheduled with the Huntsville Utilities' Inspector. Copies of Huntsville Utilities approved drawings must be available at the job meeting. In this meeting, the entire layout of the job will be considered and discussed. Any, or all, electrical installation(s) will likely be rejected if a meeting is not held before starting the job.
- 1.2 The Contractor should become familiar with Huntsville Utilities' job print and Specifications for Installation of Underground (including Specification Drawings in Appendix A) prior to the initial job meeting.
- 1.3 The job meeting should be attended by a Contractor representative who will be on site during construction and by whoever is performing the excavation.
- 1.4 The purpose of inspections is to assure conformation to all required specifications. In order to maintain a quality electrical system, the Inspector will inform the Contractor what is expected of him and will work with him to achieve these requirements.
- 1.5 Appointment(s) must be made with the Inspector to inspect completed work as the work progresses. **Do not cover up the installation before inspection is made.** It is the responsibility of the Contractor to call for inspection when needed.
- 1.6 **A 24-hour notice must be given for inspections.** Any emergency inspection(s) must be set up through the Inspector only, at the discretion of the Inspector. Inspections will normally be scheduled on regular business-days between 8 AM and 3:00 PM. If the Contractor has not requested an inspection or has covered up his installation before being inspected, Huntsville Utilities reserves the right to have the Contractor uncover any or all of the installation necessary to assure conformity to these specifications.

- 1.7 Upon completion, the Inspector will certify that the installation is visibly correct. It **must pass this visible inspection** before cable is pulled. However, **this will not constitute acceptance of the installation by Huntsville Utilities**. Huntsville Utilities' final acceptance is made when the cable is pulled and energized. The Contractor may be called back to clear or repair any conduit, level pads or any other that prevents a quality installation, and to assure conformity to these specifications. **The Contractor may be called back to make such repairs up to 1 year after cable has been pulled**. If the Contractor is unavailable, the Owner/Developer will be held responsible for repairs/corrections.
- 1.8 Any empty conduit installed by the Owner/Developer for future use will be the Owner/Developer's responsibility to repair or replace if conduit is unusable at the time it is needed.
- 1.9 No Final Inspection will be made without 100% payment of ATC.
- 1.10 Any unique situation arising in connection with any job not covered by these specifications will be resolved at the discretion of the Inspector to benefit the quality installation of Huntsville Utilities facilities.

2.0 CONDUIT (also see drawings for trench and conduit in Appendix A)

2.1 GENERAL INSTALLATION

- 2.2 Developer to furnish and install all conduit for job per drawing(s) currently supplied or approved by Huntsville Utilities Engineering Services. **NOTE:** Inspector can only work from Huntsville Utilities' approved prints/drawings.
- 2.3 Unless otherwise instructed by Huntsville Utilities, all trenched in conduit shall be gray Schedule 40, 90EC PVC, which complies with NEMA TC-2 (Conduit), and ANSI/UL-651. Each piece of conduit or fitting shall have a UL label molded or stamped on the piece. All conduit installed by boring shall be continuous, red in color, SDR 13.5.
- 2.4 Marking tape is required with any trenched conduit installation as specified in the MARKING TAPE section. Marking tape must be supplied by Huntsville Utilities.
- 2.5 Conduit shall not be covered until inspected and approved by the Huntsville Utilities Inspector.
- 2.6 If inclement weather threatens before conduit inspection is made, every other 10' section may be covered, leaving all joints, angles, water crossings, and sewer crossings open. This is maximum coverage, otherwise conduit must be completely exposed for inspection.
- 2.7 All conduits shall be run in required easements or ROW as shown by prints and/or drawings provided by Huntsville Utilities.
- 2.8 All conduit must lay flat in ditch for both single and multiple conduit runs. No stacking will be permitted unless special permission is given by the Inspector.
- 2.9 A pull line of 1/8-inch nylon or polypropylene cord shall be blown in each conduit, regardless of length. 10' of slack shall be left at each end of the conduit. Conduit shall be

blown clean and dry and all glue should be dry prior to installation of pull line.

- 2.10 Ten feet of slack shall be left inside the conduit on each end. If the conduit terminates inside a fixture the string shall be secured to the fixture or base inside the fixture. No part of the pull string shall be taught. If the conduit terminates outside a fixture the string shall be secured to the end of the conduit; with ten feet of slack inside the conduit and one foot of string secured outside the conduit.
- 2.11 All conduits shall be capped or taped closed after installation of pull string, in such a manner that the conduit can be accessed without damage to or loss of the string.

2.12 ANGLES & TURN-UPS

- 2.13 Heat bent conduit will not be accepted.
- 2.14 Minimum distance between any elbows/angles will be 4'.
- 2.15 Any conduit run using more than four bends (including turn-ups) will be rejected.
- 2.16 CONCRETE ENCASUREMENT: Required for any turn-up for any single conduit run over 500' and for any 6" galvanized turn-up. At the Huntsville Utilities' Inspector's discretion, any conduit run and/or bends may be required to be encased in concrete (thickness of concrete to be determined by Huntsville Utilities Inspector) for physical protection and/or support.
- 2.17 GALVANIZED 90E BENDS: Required for all bends in any run of primary conduit over 300', all bends in any run of primary conduit with three or more bends, and any turn-up for any future primary conduit.
- 2.18 FUTURE CONDUIT: All future primary and secondary conduit runs shall be stubbed out ten feet from the fixture where they originate toward the direction they will eventually terminate. Service conduits shall stub out at an angle toward the lot intended to serve. All future conduits shall have a pull string installed as described in this specification.
- 2.19 MARKING STUB-OUTS: All future conduits shall be marked by a matching piece of conduit extending from the buried end of the future conduit straight up two feet above final grade.
- 2.20 When conduit turns up at a power pole, it shall be located directly against pole. **Pole must be set before turn-up is installed, which requires ATC payment.** If the pole is to be set in a rocky or unstable area, the Huntsville Utilities Inspector may require installation of a Pole Sleeve by the contractor.

2.21 DEPTH & CLEARANCES

- 2.22 Conduit depth described in these specifications is the minimum depth required. Maximum depth, unless otherwise approved by the Inspector, is twice the required minimum depth.
- 2.23 Note that other utilities may have clearance requirements beyond what is required by Huntsville Utilities. The contractor is responsible for making sure all utilities' requirements are met.

- 2.24 All primary conduit must have minimum 42” of cover at sub-grade. All secondary conduit must have minimum 24” of cover at sub-grade. Any secondary conduit in the same trench as primary conduit must have 42” of cover at sub-grade. No digging shall start until grade is within 6” of sub-grade.
- 2.25 In some situations, conduit depth may be reduced to 30” by using 24” of clean fill in addition to covering the conduit with concrete (6” on top and 4” on the sides). **NOTE:** Special permission to for this type of installation must be obtained from Electric Inspector.
- 2.26 UNDER ROW: When installed along or under a roadway or right-of-way, primary and secondary conduits must be 42” below the lower of the roadway sub-grade or sub-grade directly above the conduit.
- 2.27 UNDER DRAINAGE DITCH: All conduits crossing any open ditch may be required to be encased in concrete from top of bank to top of bank, and must maintain 42” minimum cover at the lowest point of the ditch.
- 2.28 PARALLEL TO DRAINAGE DITCH: Any conduit running parallel to a drainage ditch (below top of bank) may be required to be encased in concrete.
- 2.29 PARALLEL TO OTHER FACILITIES: 5’ minimum horizontal clearance to any parallel facilities is required. Greater separation may be required around electrical fixtures. See the FIXTURES section of these specifications and the fixtures drawings in Appendix A.
- 2.30 CROSSING OTHER FACILITIES: All electrical conduits crossing under or over water and/or gas lines shall have required depth and have 12” minimum radial clearance from all water and/or gas lines. Select fill must be used and concrete support and/or spacers may be required. **NOTE:** Special permission to cross above the water line must be obtained from the Electric and Water Inspectors.
- 2.31 SEWER LATERALS: Sewer laterals shall extend 5’ beyond the electrical conduit away from the ROW.
- 2.32 JOINT TRENCH: Special permission must be obtained from all parties for joint trench installations. In some cases, the Inspector may allow communications conduits to be installed in the same trench with the electrical conduits, at the same level as the marking tape.
- 2.33 Street lighting conduit may not be necessary if fixture is located immediately adjacent to a transformer. However, for lights located more than 5’ from the source fixture, a 2” gray PVC conduit will be necessary. This conduit shall be located as indicated on the job site layouts furnished by Huntsville Utilities. In addition, splice pits (below ground street light pedestals) shall be installed by the Developer as indicated on the job site layouts.
- 2.34 Huntsville Utilities inspectors will inspect all service and secondary conduits and facilities to the stub out point. If the cable cannot be pulled when the secondary or service conduit is connected, the Developer may be required to correct the problem.

3.0 TRENCH (also see drawings for trench and conduit in appendix A)

- 3.1 **TRENCH DEPTH:** Trench depth to be determined by conduit specifications. Trench shall be clean, level and as straight as possible. **NOTE:** Any deviation in ditch must be approved by the Huntsville Utilities' Inspector.
- 3.2 **COMPACTION:** Street trenches to be compacted to jurisdictional requirements. Non-street trenches to be compacted to surrounding area.
- 3.3 **JOINT TRENCH:** Joint trench installations may be allowed or required under certain circumstances and requires prior approval of the Huntsville Utilities Inspector. Minimum clearances must be met as detailed in the drawings that will be supplied by the Huntsville Utilities Inspector for the specific project. Joint trench installation may require the use of conduit spacers and/or concrete encasement to ensure minimum clearances are maintained.
- 3.4 **MARKING TAPE:** All trench installations require installation of marking tape as described in the MARKING TAPE section and in the drawings in Appendix A)
- 3.5 **ROW CROSSINGS:** ROW crossings may require special permission and/or permits from local jurisdiction. The Contractor is responsible for securing any such permission and/or permits.

4.0 MARKING TAPE (also see drawings for trench and conduit in Appendix A)

- 4.1 Marking tape is required over all primary and street light conduits, and secondary conduits run in a ROW or dedicated U&D easement. Marking tape may not be required over secondary conduits if on private property to a residence on that property (check with the Inspector for clarification).
- 4.2 Marking tape must be inspected before being covered. However, tape should be secured at time of installation by spot filling (2-3 shovels of dirt) every 5'.
- 4.3 Ditch shall be leveled and tape shall be installed flat in ditch directly above conduit(s).
- 4.4 Depth of marking tape shall be 30" above conduit for any conduit with 42" or more of cover, and 12" above conduit for any conduit with less than 42" of cover.
- 4.5 If conduit is encased in concrete, an additional layer of marking tape is required directly on top of the concrete.
- 4.6 Only electrical marking tape furnished by Huntsville Utilities will be accepted. Marking tape may be picked up at Chase Warehouse and requires partial payment of ATC as directed in Section 0 of this specification.

5.0 FIXTURES (also see drawings for fixtures in Appendix A)

- 5.1 Developer to install all fixtures, pads, and pedestals required for job according to the job drawing and the appropriate Specification Drawings (attached in Appendix A). See Section 0 regarding required ATC payment for material pickup.

- 5.2 Fixture installation specifications are designed such that the resulting installation offers safe and efficient accessibility to fixtures for maintenance and operation, and that the fixture location is selected to minimize incidental damage to fixtures. In some cases this will require installation of a paved access road to a fixture location. Because ‘accessibility’ can vary depending on the site layout, the final decision regarding whether or not a fixture is accessible will be determined by the Huntsville Utilities Inspector.
- 5.3 Note that other utilities may have clearance requirements beyond what is required by Huntsville Utilities. The contractor is responsible for making sure all utilities’ requirements are met.
- 5.4 All fixtures shall be located within the Utility and Drainage Easement a consistent distance from back of curb or property pin.
- 5.5 Guard posts may be required at or around any fixture or pad at the discretion of the Inspector. This is especially likely if fixture is located near traffic. See drawings for guard post installation.
- 5.6 Fixture installation will not be approved until curb and gutter are installed (pavement if no curb and gutter) to assure finished grade requirements.**
- 5.7 All fixtures shall have level, unimpaired minimum clearances on all sides (clear zones) to assure quality of installation and maintenance. No shrubbery, fencing, or other obstructions shall be allowed in these areas. Note the clear zones specified in the Specification Drawings.
- 5.8 No fire hydrants, phone or TV cable pedestals will be permitted directly in front of any Huntsville Utilities electrical fixtures.
- 5.9 Do not stub up any communications facilities (such as cable TV or telephone) in front of or within three 3’ of any Huntsville Utilities facilities (fire hydrant, pedestal, transformer, etc.). This includes existing fixtures and fixtures shown as proposed on any job drawings for the project. The ‘front’ of Huntsville Utilities’ electrical fixtures refers to the opening side of the fixture, and will normally face the road.
- 5.10 All walls constructed around any fixture(s) shall allow required clearances and be properly ventilated to permit proper cooling and safe operation of equipment. Maximum allowable height of walls is 8’.
- 5.11 There must be minimum 4’ horizontal clearance from any fixture to any fire hydrant (in addition to any clear zones otherwise noted in these specifications).
- 5.12 The thickness of the concrete pad shown in UP-3A is dependent on the location of the pad. Consult Huntsville Utilities’ Electric Inspector for the required thickness.
- 5.13 No secondary cables shall be pulled before the transformer is placed by Huntsville Utilities. If cables are pulled before the transformer is placed, Huntsville Utilities will require the secondary cables to be removed before placing the transformer. Note that secondary cables are supplied and installed by the customer for commercial installations and for residential installations 400 amp and larger.
- 5.14 Curb and gutter must be installed before any concrete pads may be formed.

6.0 VAULTS AND MANHOLES (specification drawings will be supplied if needed)

- 6.1 The Developer shall install any necessary vaults and manholes. **NOTE:** Contact Huntsville Utilities Electric Inspector before installation begins.
- 6.2 These vaults and manholes are specialty items. Huntsville Utilities will work with the Developer on getting these items directly to the job site as needed.

7.0 SLOPE INSTALLATIONS (specification drawings will be supplied if needed)

- 7.1 The ground surrounding the facilities within the required minimum clearance zone shall be level, and shall be properly tamped. Additional minimum clearance distances may be required, particularly on steeper slopes. Contact Huntsville Utilities Electric Inspector for required clearances.
- 7.2 If facilities are installed on cut areas, the adjacent sloped area which slopes down towards the facilities shall be properly tamped and reinforced:
 - A. For slopes up to 45E, reinforcement can be sod or concrete with rip-rap as approved by the Inspector for a particular site.
 - B. For slopes greater than 45E, a properly tied and reinforced retaining wall may be required.
 - C. The terrain shall be sloped in such a manner as to divert run-off away from all vaults, transformers, pedestals, etc., and to avoid possible erosion over conduit runs.
- 7.3 If facilities are installed on fill areas, the adjacent sloped area which slopes away from the facilities shall be properly tamped, and reinforced:
 - A. For slopes up to 45E, reinforcement can be sod or concrete with rip-rap as approved by the Inspector for a particular site.
 - B. For slopes greater than 45E, a properly tied and reinforced retaining wall may be required.
 - C. The terrain shall be sloped in such a manner as to avoid erosion over conduit runs or which might threaten to undermine the slope supporting Huntsville Utilities facilities.
 - D. The sloped area shall be properly drained to avoid any mobility of the fill.

8.0 SECONDARY AND METERING

- 8.1 Any meter socket used (provided by the Owner/Developer/Contractor) must be on the Approved Meter Socket list (available from your Inspector or at www.hsvutil.org).
- 8.2 Enclosed meter rooms or closets are generally not allowed and are not covered under the scope of this specification. Special permission must be obtained from Huntsville Utilities

prior to the construction of the meter room or closet. The Huntsville Utilities Inspector can provide contact information for the Meter Shop.

- 8.3 Secondary/service conduits terminating in a transformer are limited depending on the size of the transformer and conduits and any CT's required for metering. If more than 6 conduits (ie 4 sets of secondary/service conductors) are required then special permission must be obtained from the Huntsville Utilities Inspector. In some cases a second transformer may be required.

9.0 ACCESS ROADS

- 9.1 When any fixture is six feet or greater away from the curb, an access road may be required (asphalt or concrete).
- 9.2 Access road shall be constructed of asphalt or load bearing concrete.
- 9.3 Thickness and width of road to be determined by the inspector on an individual job basis.
- 9.4 Asphalt road installations must meet parking lot standards.

Appendix A Specification Drawings

GP-1	Guard Post Installation
PECI	Electric Conduit Installation
SP-1	Below Ground Street Light Pedestal
SP-2	Above Ground Secondary Pedestal – Standard
SP-3	Above Ground Secondary Pedestal – Large
UC-2	Conduit Elbow Encasement
UP-1	Single-Phase Transformer Pad Installation
UP-3A	Three-Phase Transformer Pad Specification
UP-3B	Fiberglass Three-Phase Transformer Pad
UP-4	Three-Phase Sectionalizing Cabinet Base
UP-5	Single-Phase Sectionalizing Cabinet
UP-7	Concrete Pad Steel Reinforcement Layout
UP-9	Rock Area – Pole Sleeve
UP-10	Switch Gear

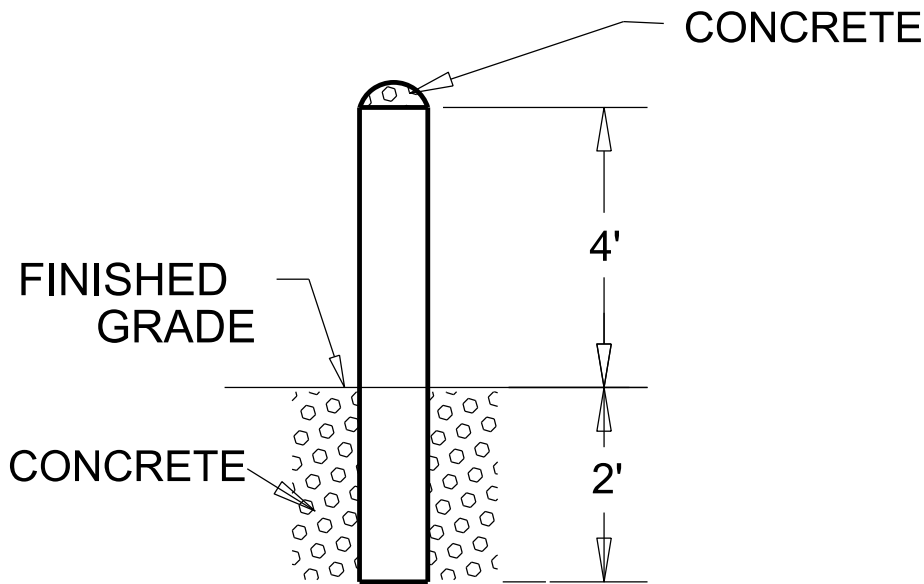

SIDE VIEW

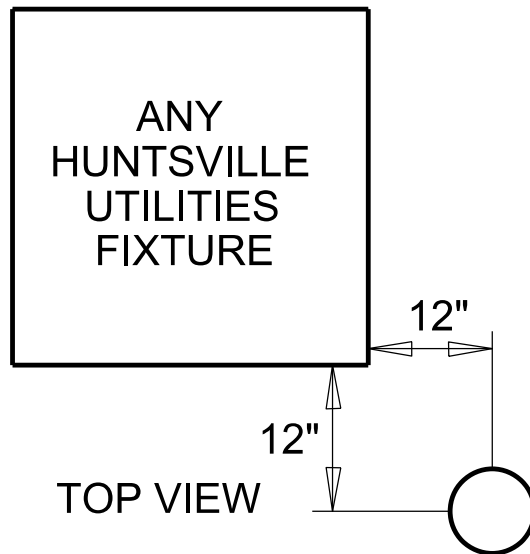

TOP VIEW

1. GUARD POSTS TO BE 3" IN DIAMETER OR BIGGER.
2. GUARD POSTS MAY BE REQUIRED AROUND ANY FIXTURE. LOCATIONS WILL BE DETERMINED BY A HU REPRESENTATIVE.
3. GUARD POSTS REQUIRED WHEN FIXTURE IS WITHIN 5' OF TRAFFIC

DWN J. PATTERSON DAT 11/11/97	NO.	DATE	REVISION
	1	10/30/03	ADD NOTE AND REVISED DWG.
CKD DAT	2	01/04/05	ADD NOTE AND REVISED DWG.
APP M. CAGLE DAT 10/30/03	3	10/07/08	ADD NOTE AND REVISED DWG.
APP M. CAGLE DAT 01/04/05	4	09/04/13	ADD NOTE AND REVISED DWG.
APP J. BROWN DAT 09/04/13			

ELECTRIC DEPARTMENT

GP-1

GUARD POST
INSTALLATION



GENERAL SPECIFICATIONS FOR INSTALLATION OF UNDERGROUND UTILITIES

TYPICAL ELECTRIC PRIMARY CONDUIT INSTALLATION

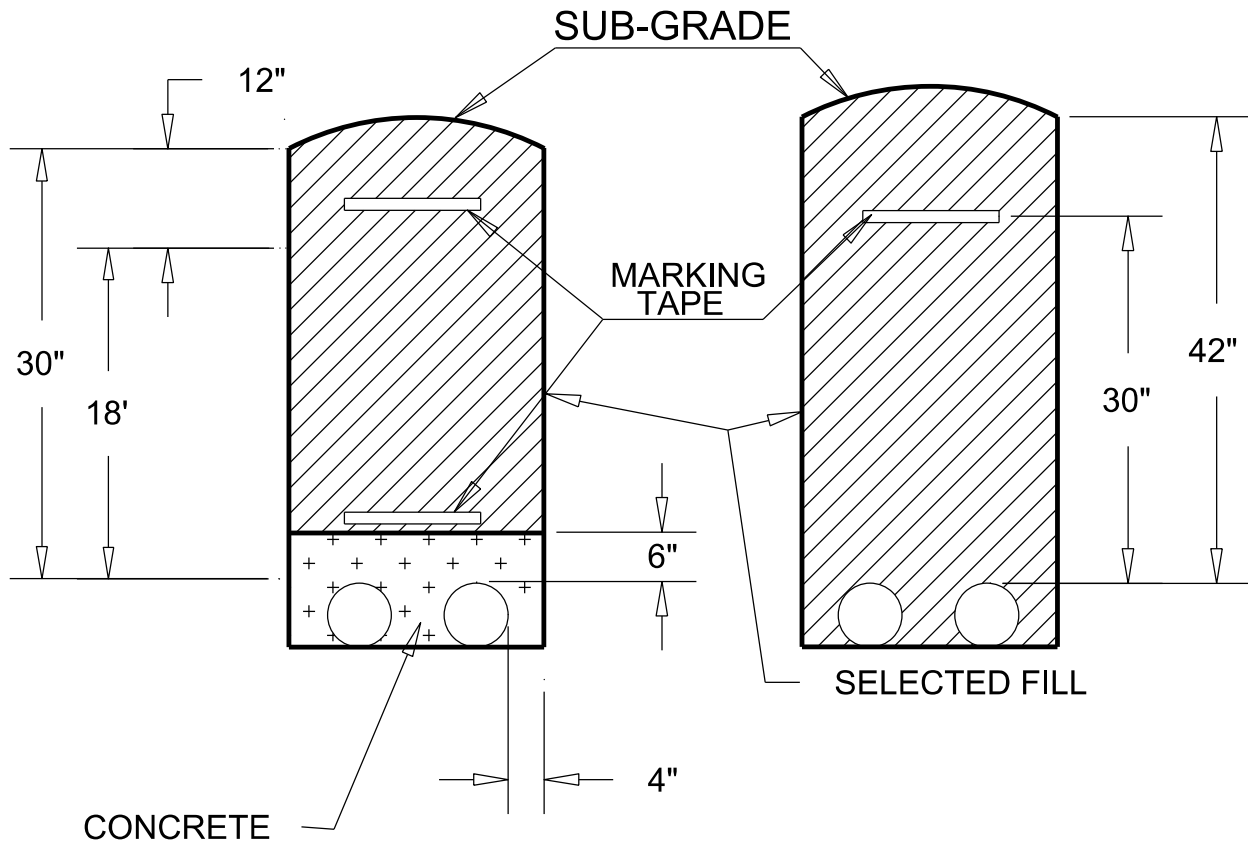

1. TRENCH WIDTHS WILL VARY WITH QUANTITY OF CONDUITS INSTALLED.
2. ALSO SEE SPECIFICATIONS FOR PRIMARY AND/OR SECONDARY CONDUIT INSTALLATION
3. CONCRETE SHOWN FOR DEPTH REDUCTION IN ROCKY AREAS. IF CONCRETE IS REQUIRED FOR STABILITY THEN COMPLETE ENCASEMENT MAY BE REQUIRED.

DWN J. PATTERSON DAT 11/11/97	NO. 1	DATE 10/07/08	REVISION ADD NOTE AND REVISED DWG.
CKD DAT			
APP J. BAILEY DAT 10/07/08			
APP DAT			
APP DAT			

ELECTRIC DEPARTMENT

PECI

TYPICAL ELECTRIC PRIMARY CONDUIT INSTALLATION

GENERAL SPECIFICATIONS FOR INSTALLATION OF UNDERGROUND UTILITIES



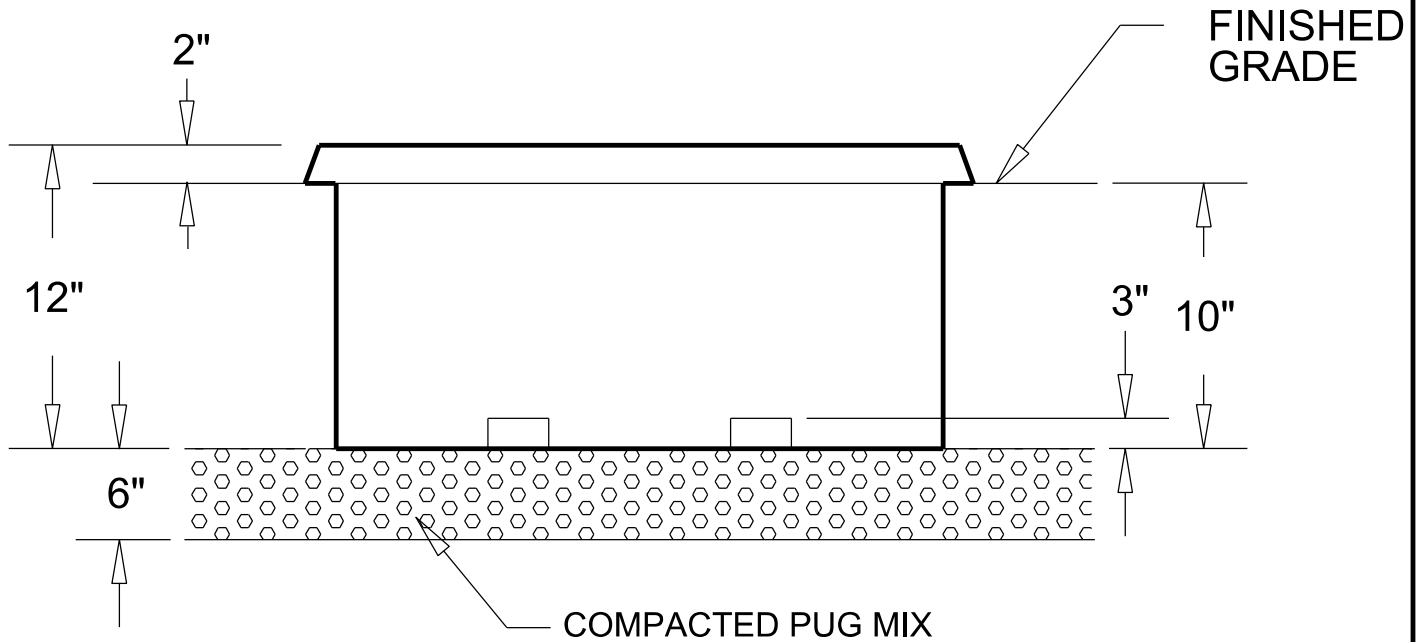

NOTES:

1. UNIT TO BE PLACED ON A 6" COMPACTED PUG MIX BASE.
2. CONDUITS TO TERMINATE 3" ABOVE PUG MIX.
3. UNIT BOTTOM TO BE 10" BELOW FINAL GRADE.
4. UNIT TO BE UPRIGHT AND PLUMB.
5. FOR NUMBER AND SIZE OF CONDUITS, CONSULT JOB DRAWING.

DWN J. PATTERSON DAT 11/11/97	NO.	DATE	REVISION
CKD DAT	1	03/19/04	EDITED TEXT
APP M. CAGLE DAT 03/19/04	2	01/05/05	REVISED DWG. AND EDITED TEXT
APP M. CAGLE DAT 01/05/05	3	10/07/08	EDITED TEXT
APP J. BAILEY DAT 10/07/08			

ELECTRIC DEPARTMENT	
SP-1	BELOW GROUND STREET LIGHT PEDESTAL
GENERAL SPECIFICATIONS FOR INSTALLATION OF UNDERGROUND UTILITIES	



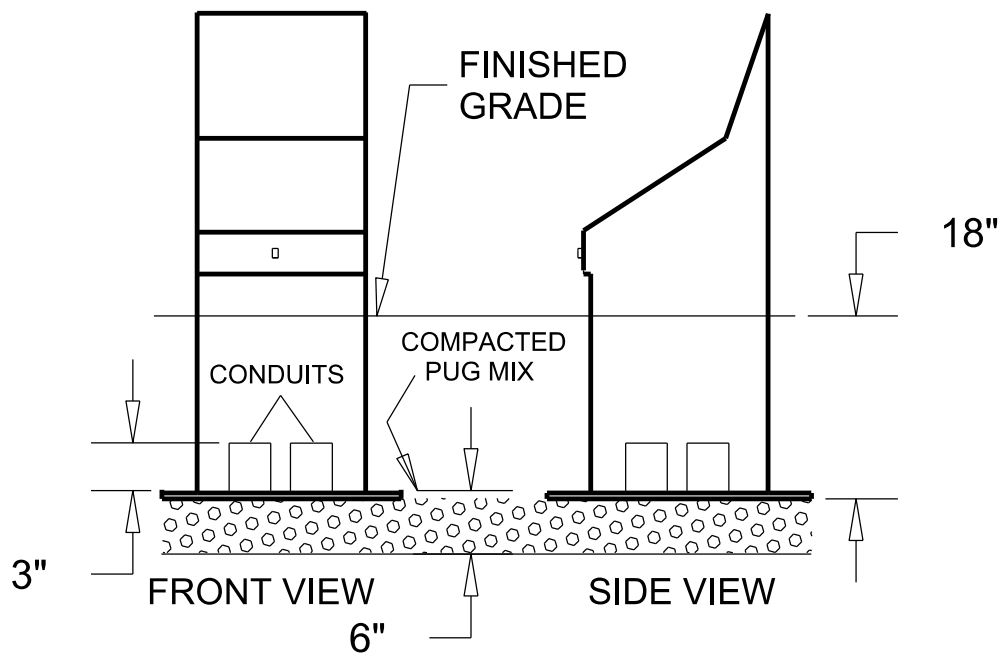
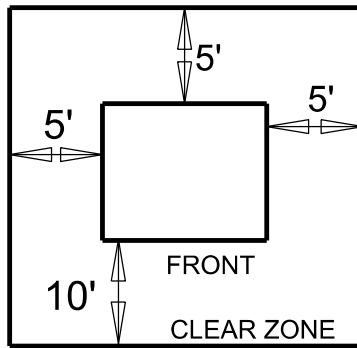

NOTES:

1. UNIT TO BE PLACED ON A 6" COMPACTED PUG MIX BASE.
2. CONDUITS TO TERMINATE 3" ABOVE PUG MIX.
3. UNIT BOTTOM TO BE 18" BELOW FINAL GRADE.
4. UNIT TO BE UPRIGHT AND PLUMB.
5. FOR NUMBER AND SIZE OF CONDUITS, CONSULT JOB DRAWING.
6. SIZE AND SHAPE OF FIXTURE MAY VARY.

DWN J. PATTERSON DAT 11/11/97	NO.	DATE	REVISION
	1	03/19/04	EDITED TEXT
CKD DAT	2	01/05/05	REVISED DWG. AND EDITED TEXT
APP M. CAGLE DAT 03/19/04	3	10/07/08	EDITED TEXT
APP M. CAGLE DAT 01/05/05	4	09/04/13	REVISED DWG. AND EDITED TEXT
APP J. BROWN DAT 09/04/13			

ELECTRIC DEPARTMENT

SP-2

**ABOVE GROUND
STANDARD
PEDESTAL**

GENERAL SPECIFICATIONS FOR INSTALLATION OF UNDERGROUND UTILITIES



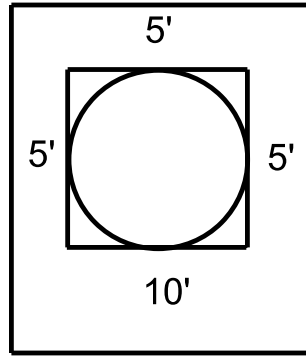

FRONT SIDE

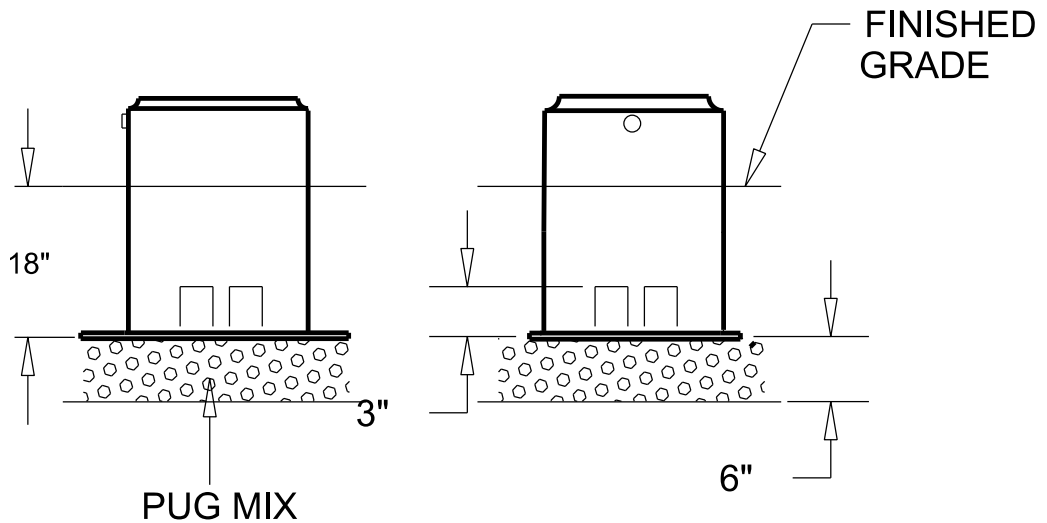

NOTES:

1. UNIT TO BE PLACED ON A 6" PUG MIX BASE.
2. CONDUITS TO TERMINATE 3" ABOVE PUG MIX.
3. UNIT BOTTOM TO BE 18" BELOW FINAL GRADE.
4. UNIT TO BE UPRIGHT AND PLUMB.
5. FOR NUMBER AND SIZE OF CONDUITS, CONSULT JOB DRAWING.

DWN J. PATTERSON DAT 11/11/97	NO.	DATE	REVISION
	1	03/19/04	EDITED TEXT
CKD DAT	2	09/04/13	EDITED TEXT
APP M. CAGLE DAT 03/19/04			
APP J. BROWN DAT 09/04/13			
APP DAT			

ELECTRIC DEPARTMENT

SP-3

**ABOVE GROUND
STANDARD
LARGE PEDESTAL**

GENERAL SPECIFICATIONS FOR INSTALLATION OF UNDERGROUND UTILITIES



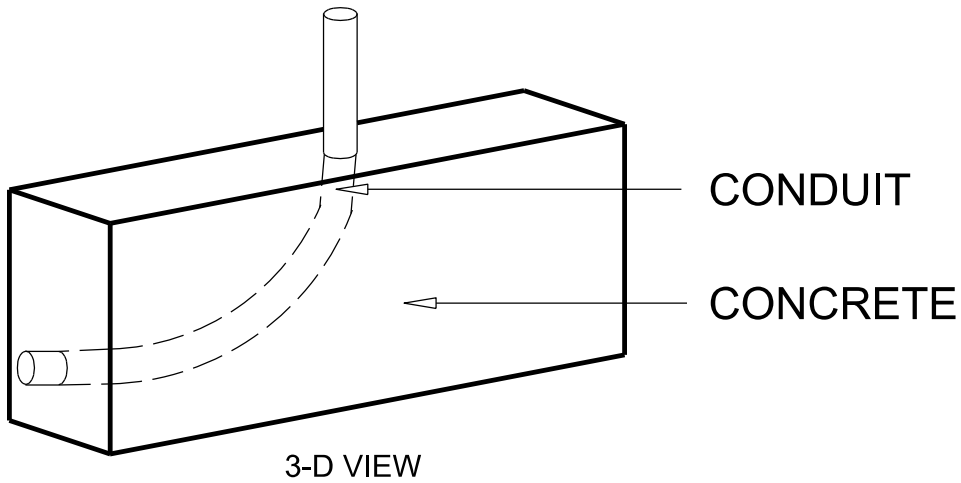
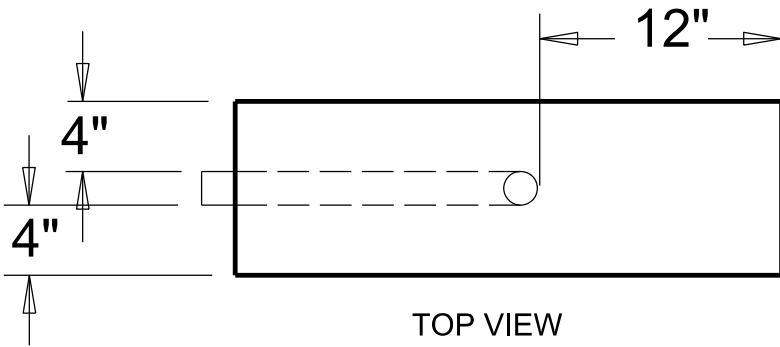
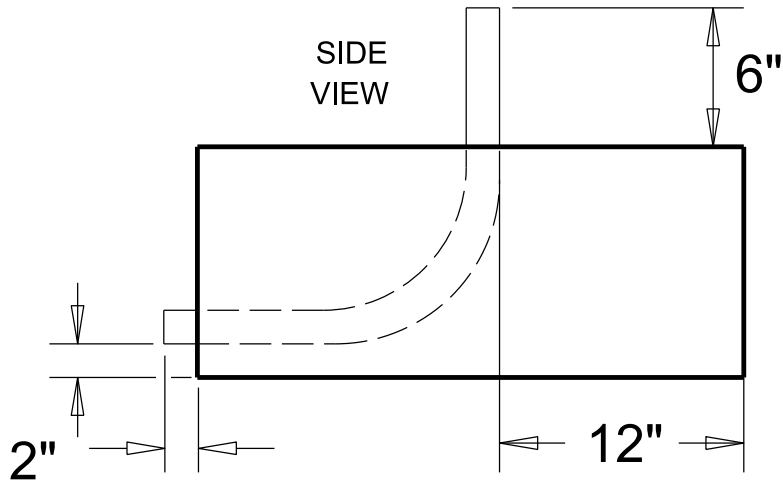

NOTE: ENCASEMENT REQUIRED PER INSPECTOR.

DWN J. PATTERSON	NO.	DATE	REVISION
DAT 11/11/97	1	03/19/04	EDIT DIM. & DELETE NOTES
CKD			
DAT	2	01/05/05	EDIT DIMENSIONS
APP M. CAGLE			
DAT 10/30/03			
APP M. CAGLE			
DAT 01/05/05			
APP			
DAT			

ELECTRIC DEPARTMENT

UC-2

CONDUIT ELBOW
ENCASEMENT

GENERAL SPECIFICATIONS FOR INSTALLATION OF UNDERGROUND UTILITIES



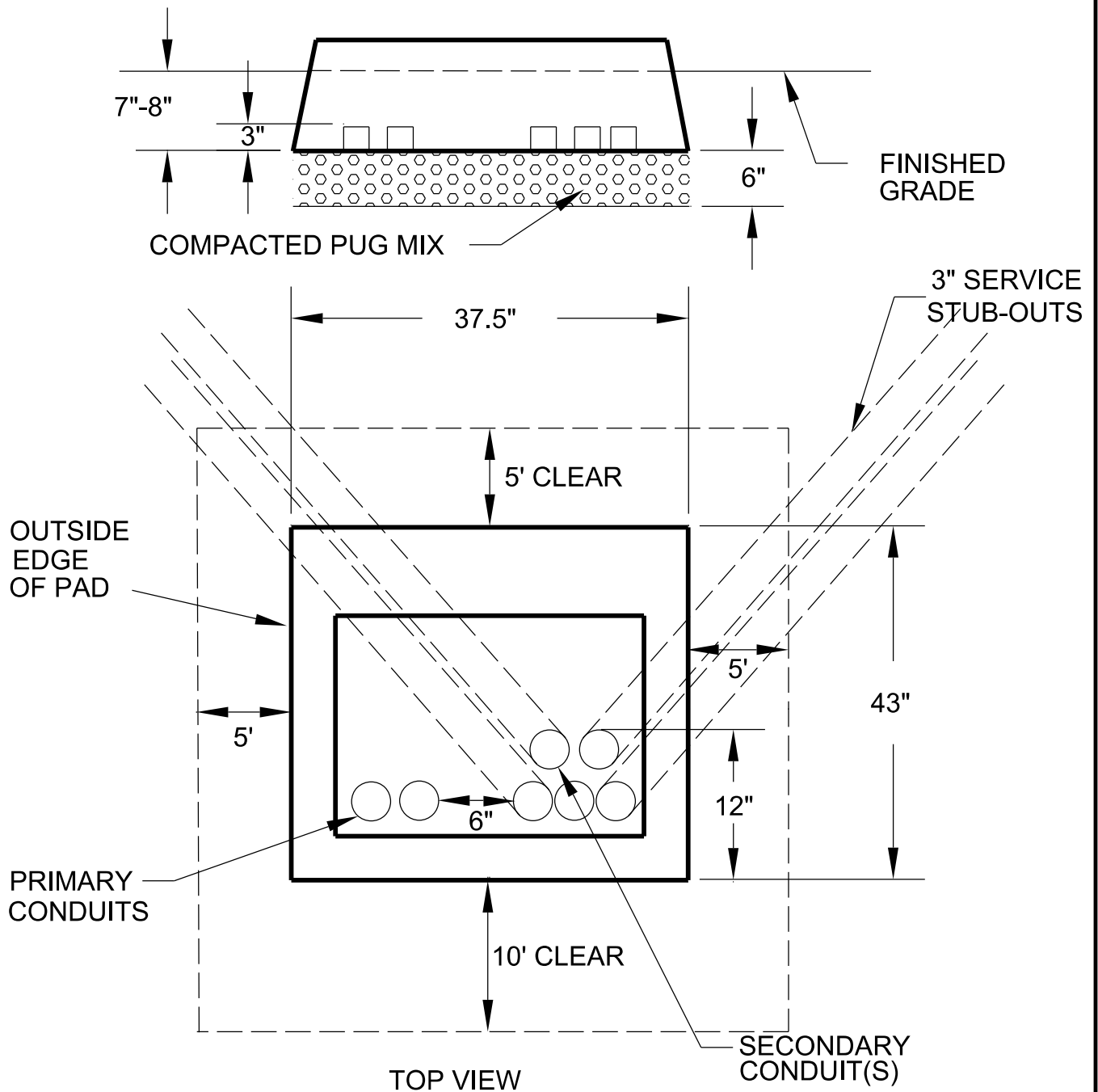

NOTE:

1. UNIT TO BE PLACED ON A 6" COMPACTED PUG MIX BASE.
2. CONDUITS TO TERMINATE 3" ABOVE PUG MIX.
3. UNIT BOTTOM TO BE 7"-8" BELOW FINAL GRADE.
4. UNIT TO BE UPRIGHT AND PLUMB.
5. FOR NUMBER AND SIZE OF CONDUITS, CONSULT JOB DRAWING.

DWN J. PATTERSON DAT 11/11/97	NO.	DATE	REVISION
	1	03/19/04	EDITED NOTES
CKD DAT	2	01/05/05	ADDED & EDITED NOTES
APP M. CAGLE DAT 01/05/05	3	10/07/08	REVISED DWG & EDITED NOTES
APP J. BAILEY DAT 10/07/08	4	09/04/13	REVISED DWG & EDITED NOTES
APP J. BROWN DAT 09/04/13			

ELECTRIC DEPARTMENT

UP-1

**SINGLE PHASE FIBERGLASS
TRANSFORMER PAD
SPECIFICATION**



GENERAL SPECIFICATIONS FOR INSTALLATION OF UNDERGROUND UTILITIES

FRONT SIDE

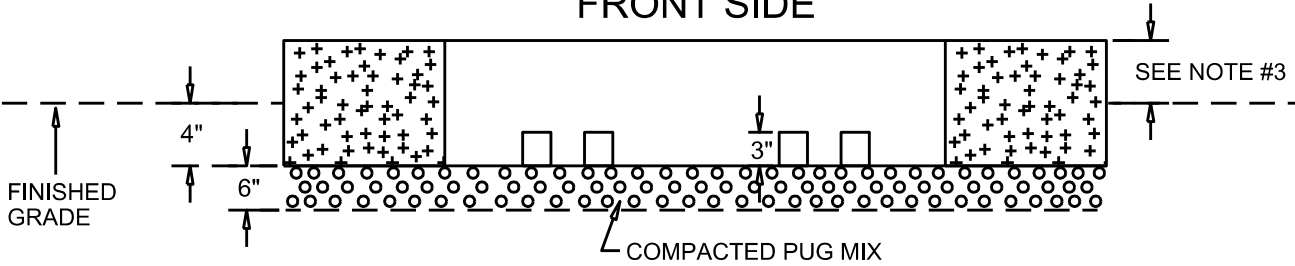

OUTSIDE EDGE OF PAD

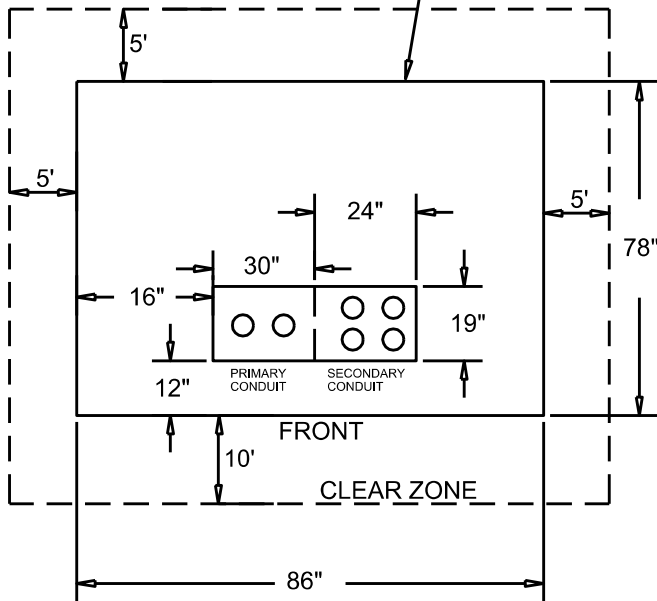

**75 TO 300 KVA
TOP VIEW**

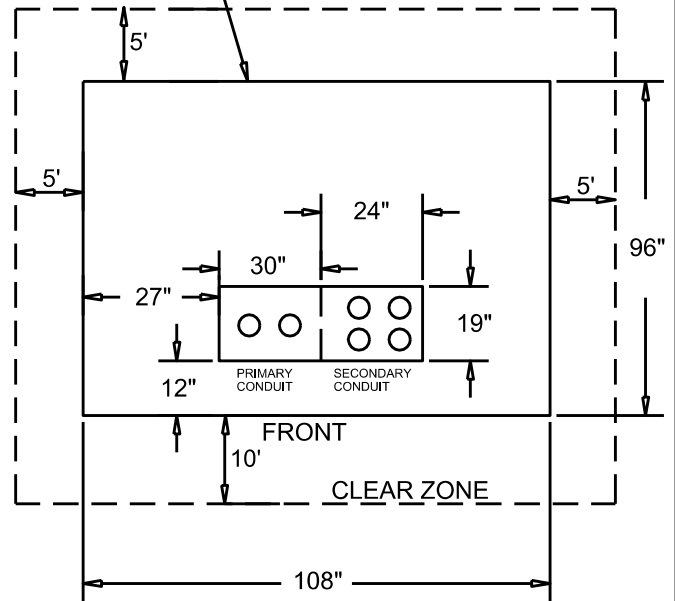

**500 TO 2500 KVA
TOP VIEW**

NOTES:

1. FOR NUMBER AND SIZE OF PRIMARY CONDUITS, CONSULT JOB DRAWING.
2. PADS MUST HAVE A BRUSHED OUTSIDE FINISH.
3. HEIGHT OF PAD WILL BE DETERMINED AT INITIAL JOB MEETING.
4. REBAR REQUIRED PER SPEC #UP-7.
5. GUARD POSTS MAY BE REQUIRED (AS DETERMINED BY A HUNTSVILLE UTILITES REPRESENTATIVE) SEE SPEC GP-1
6. NO SECONDARY CABLES MAY BE PULLED UNTIL TRANSFORMER IS PLACED.
7. FROM OUTSIDE OF PRIM. TO OUTSIDE OF SEC. EQUALS 48"
8. MINIMUM THICKNESS OF CONCRETE PAD IS 24"

DWN J. PATTERSON	NO.	DATE	REVISION
DAT 11/11/97	1	03/19/04	EDITED NOTES
CKD	2	01/05/05	ADDED & EDITED NOTES
DAT 03/19/04	3	10/07/08	REVISED DWG & EDITED NOTES
APP M. CAGLE	4	09/04/13	REVISED DWG & EDITED NOTES
DAT 01/05/05			
APP J. BROWN			
DAT 09/04/13			

ELECTRIC DEPARTMENT

UP-3A

**TRANSFORMER PAD
SPECIFICATION PAD
TRANSFORMERS
75 TO 2500 KVA**

GENERAL SPECIFICATIONS FOR INSTALLATION OF UNDERGROUND UTILITIES



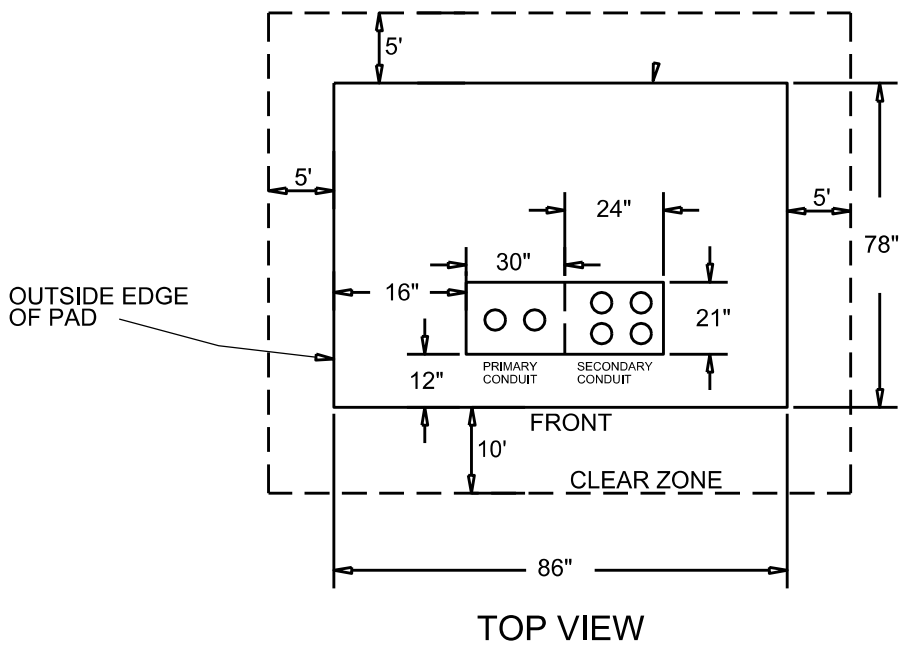
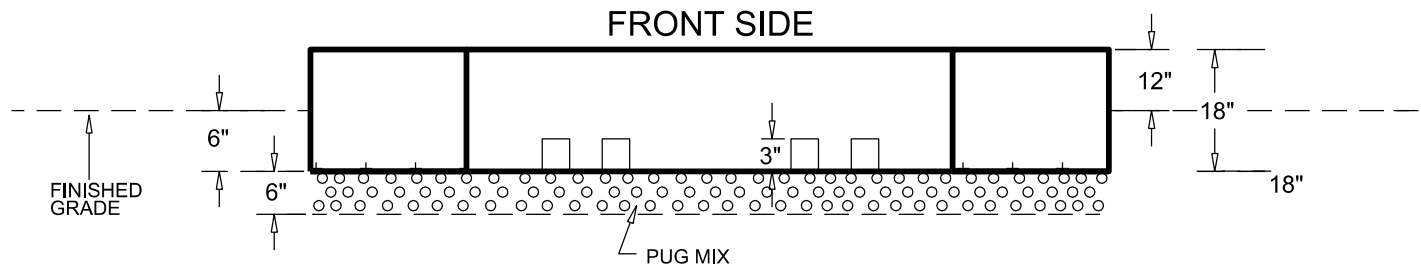

NOTES:

1. PAD BOTTOM TO BE 6" BELOW FINISH GRADE.
2. CONDUITS TO TERMINATE 3" ABOVE PUG MIX.
3. HEIGHT OF PAD WILL BE DETERMINED AT INITIAL JOB MEETING.
4. UNIT TO BE PLACED ON A 6" COMPACTED PUG MIX BASE.
5. FIBERGLASS PAD MUST BE A HUNTSVILLE UTILITIES CURRENTLY APPROVED ITEM.
6. THE USE OF A FIBERGLASS PAD REQUIRES SPECIAL APPROVAL AND ADDITIONAL ATC.
7. PAD DIMENSIONS MAY VARY DEPENDING ON VENDOR
8. GUARD POSTS MAY BE REQUIRED (AS DETERMINED BY A HUNTSVILLE UTILITIES REPRESENTATIVE) SEE SPEC GP-1

DWN J. PATTERSON	NO.	DATE	REVISION
DAT 05/05/97	1	01/05/05	ADDED & EDITED TEXT
CKD			
DAT	2	06/28/12	REVISED DWG & EDITED NOTES
APP M.CAGLE			
DAT 01/05/05			
APP J. BAILEY			
DAT 08/28/12			
APP			
DAT			

ELECTRIC DEPARTMENT

UP-3B

FIBERGLASS TRANSFORMER PAD
SPECIFICATION FOR 3PH
TRANSFORMERS
75 TO 300 KVA

GENERAL SPECIFICATIONS FOR INSTALLATION OF UNDERGROUND UTILITIES



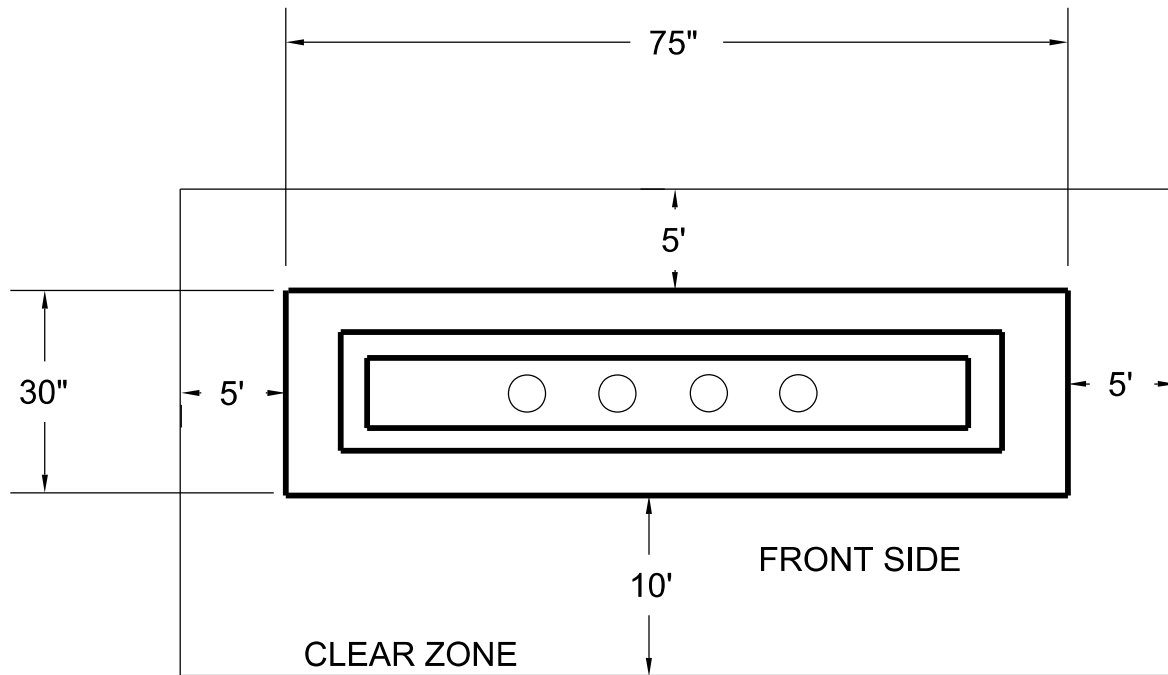

TOP VIEW

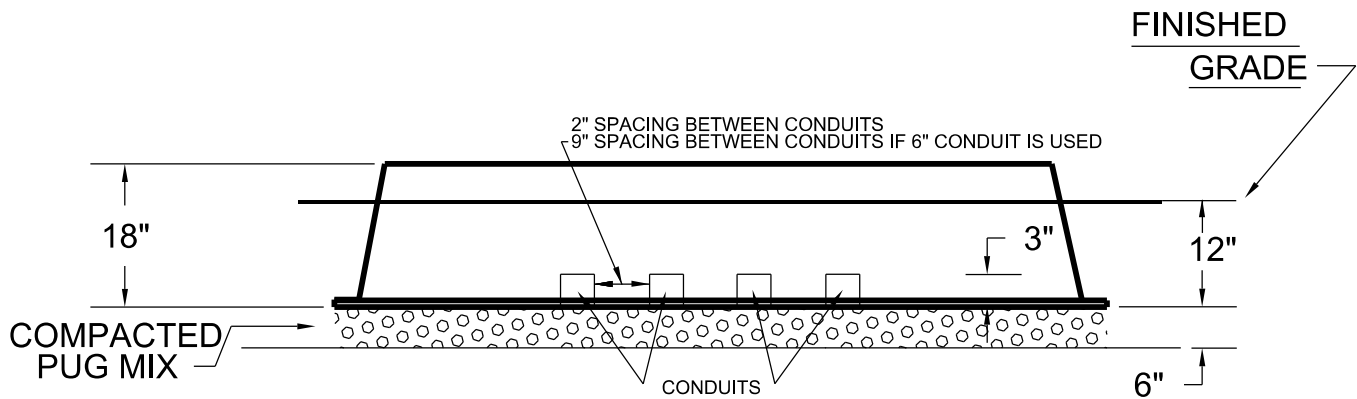

NOTE:

1. BOTTOM OF BASE TO BE BURIED 12" BELOW FINISHED GRADE.
2. CONDUIT TO BE STUBBED UP 3 INCHES ABOVE COMPACTED PUG MIX.
3. UNIT TO BE PLACED ON A 6 INCH COMPACTED PUG MIX BASE.
4. UNIT TO BE UPRIGHT AND PLUMB.
5. FOR NUMBER AND SIZE OF CONDUITS, CONSULT JOB DRAWING. AT FINISHED GRADE.

DWN J. PATTERSON DAT 11/11/97	NO.	DATE	REVISION
	1	03/19/04	EDITED TEXT
CKD DAT	2	01/05/05	ADDED & EDITED NOTES
APP M. CAGLE DAT 01/05/05	3	10/07/08	ADDED & EDITED NOTES
APP M. CAGLE DAT 01/05/05	4	09/04/13	ADDED & EDITED NOTES
APP J. BROWN DAT 09/04/13			

ELECTRIC DEPARTMENT

UP-4

THREE PHASE
SECTIONALIZING CABINET
MOUNTING BASE



GENERAL SPECIFICATIONS FOR INSTALLATION OF UNDERGROUND UTILITIES

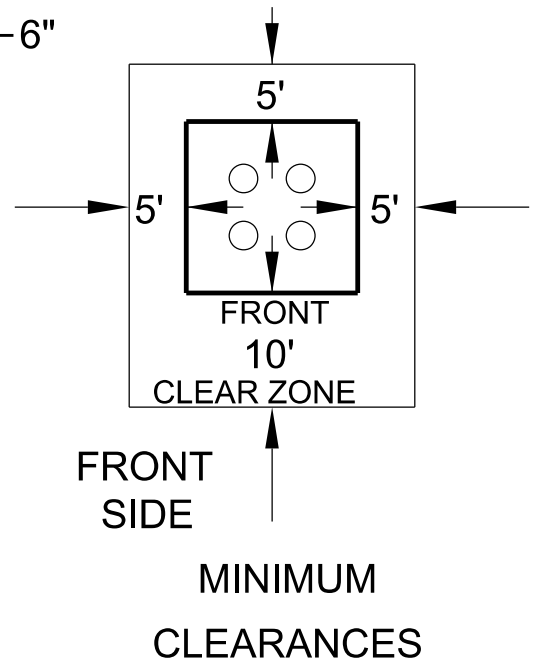
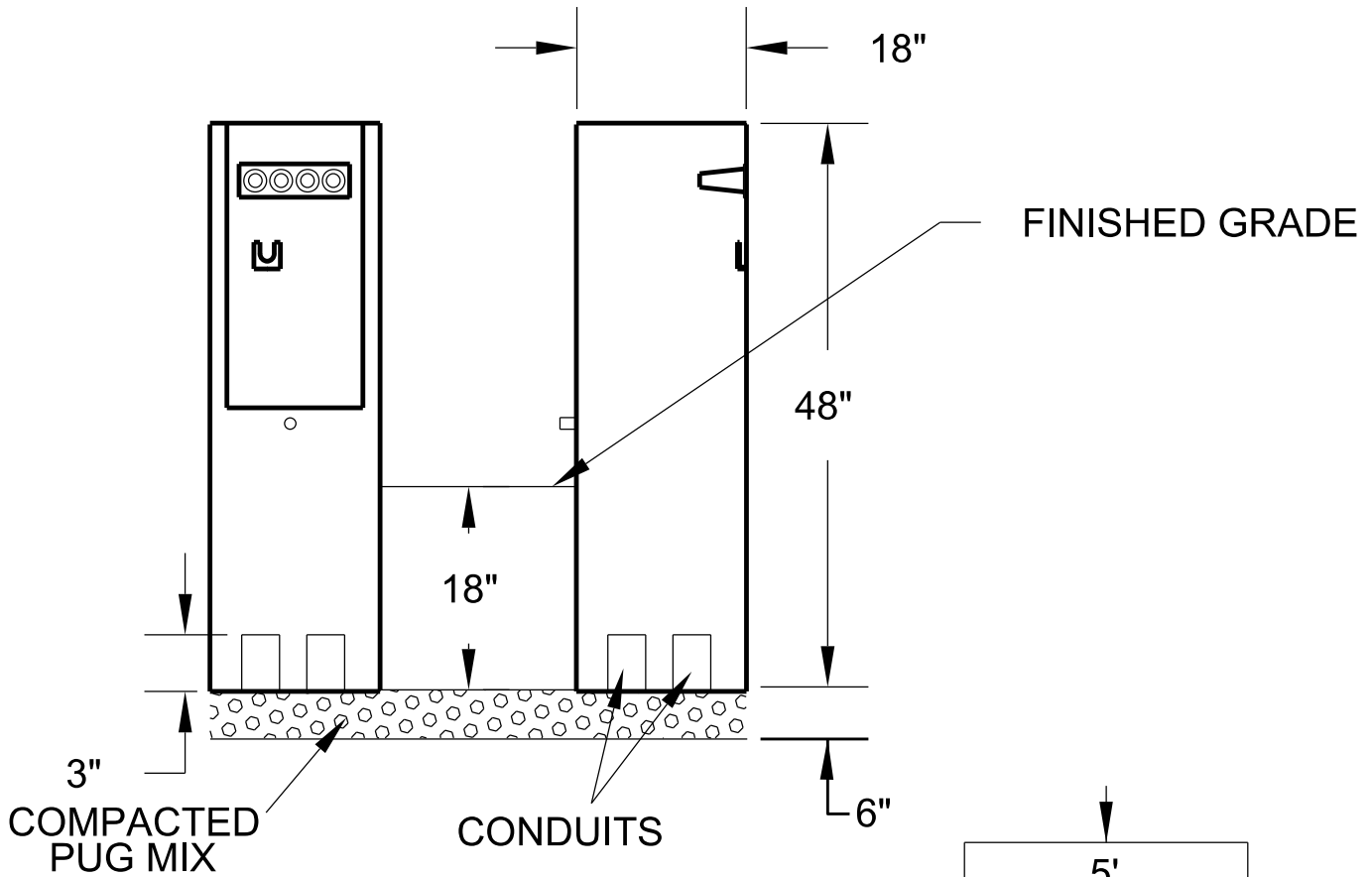

NOTES:

1. UNIT TO BE PLACED ON A 6" COMPACTED PUG MIX BASE.
2. CONDUITS TO TERMINATE 3" ABOVE PUG MIX.
3. UNIT BOTTOM TO BE 18" BELOW FINISHED GRADE.
4. UNIT TO BE UPRIGHT AND PLUMB.
5. FOR NUMBER AND SIZE OF CONDUITS, CONSULT JOB DRAWING.

DWN J. PATTERSON DAT 11/11/97	NO.	DATE	REVISION
	1	03/19/04	EDITED TEXT
CKD DAT	2	01/04/05	EDITED & ADDED NOTES
APP M. CAGLE DAT 03/19/04	3	10/07/08	REMOVED TOP VIEW
APP M. CAGLE DAT 01/05/05	4	09/04/13	EDITED TEXT
APP J. BROWN DAT 09/04/13			

ELECTRIC DEPARTMENT

UP-5

SINGLE PHASE
SECTIONALIZING CABINET



GENERAL SPECIFICATIONS FOR INSTALLATION OF UNDERGROUND UTILITIES

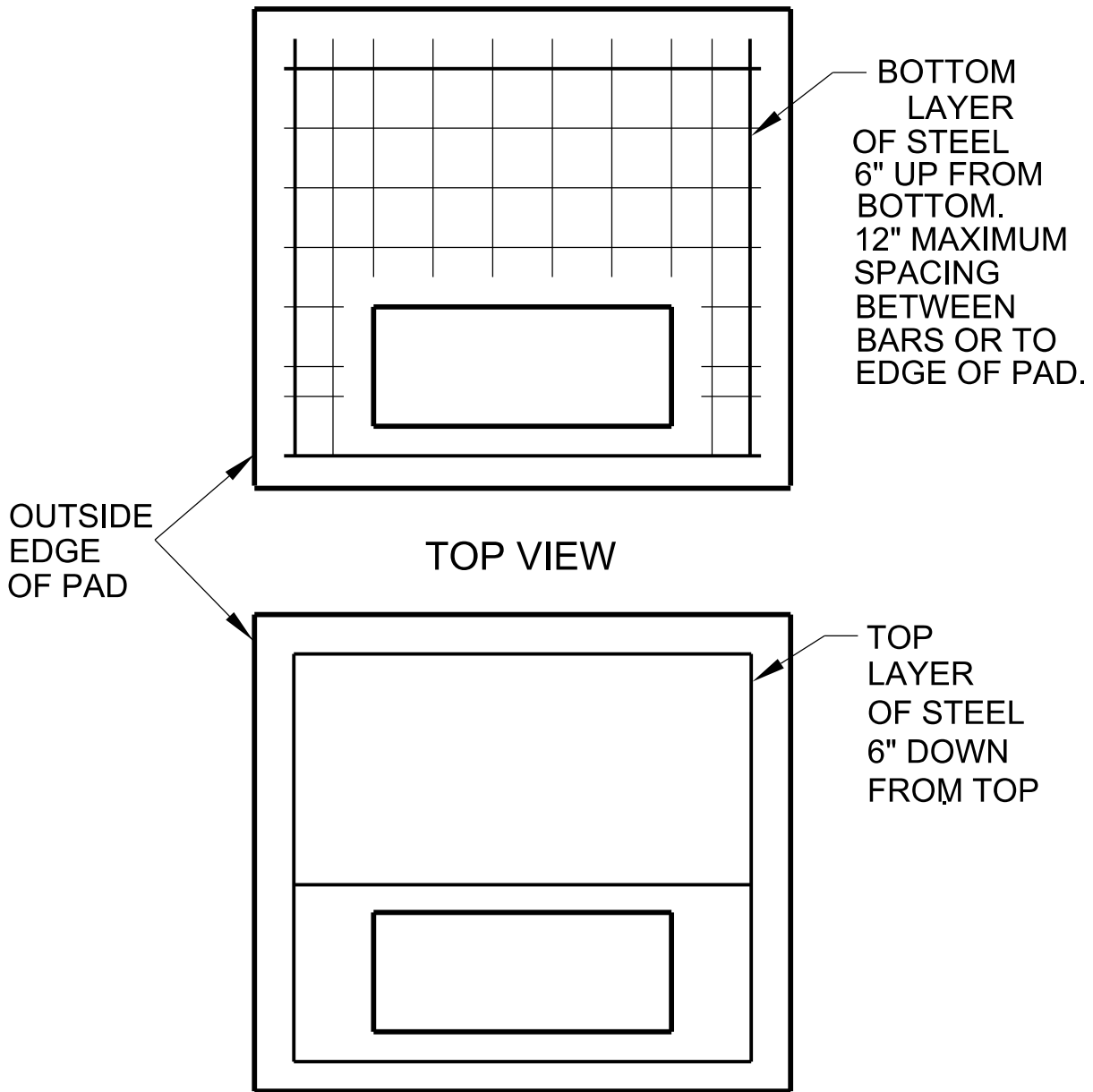

1. TWO LAYERS #4 (1/2") REBAR ARE REQUIRED.
2. IT IS NOT PERMISSABLE TO FLOAT EITHER LAYER OF REBAR.
3. NO REBAR SHOULD BE WITHIN 6" OF ANY SURFACE OF THE PAD.
4. PAD FORM (WITH STEEL INSTALLED) MUST BE INSPECTED BEFORE POURING CONCRETE.

DWN J. PATTERSON	NO.	DATE	REVISION
DAT 11/11/97			
CKD			
DAT			
APP M. CAGLE			
DAT 10/30/03			
APP M. CAGLE			
DAT 01/04/05			
APP J. BROWN			
DAT 09/04/13			

ELECTRIC DEPARTMENT	
UP-7	CONCRETE PAD STEEL REINFORCEMENT LAYOUT
GENERAL SPECIFICATIONS FOR INSTALLATION OF UNDERGROUND UTILITIES	



BACKFILL AROUND PIPE
WITH SUITABLE FILL

24" CONCRETE CULVERT
PLUMBED AND LEVELED
(SIZE CAN VARY DEPENDING
ON TYPE OF POLE TO
BE INSTALLED)

GROUND LEVEL

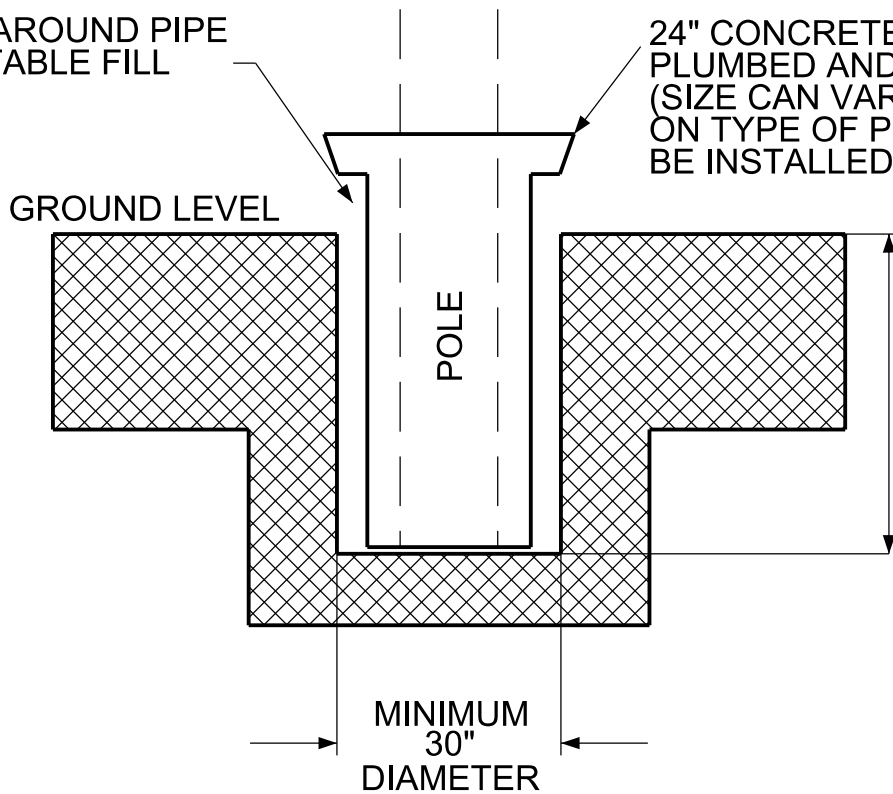

6.5' TO 7'
MIN. DEPTH
(DEPTH WILL
VARY DEPENDING
ON THE SIZE OF
THE POLE TO
BE INSTALLED)

MINIMUM
30"
DIAMETER

NOTE: CULVERT LENGTH IS 8'

DWN J. BAILEY	NO.	DATE	REVISION
DAT 10/07/08			
CKD			
DAT			
APP			
DAT			
APP			
DAT			
APP			
DAT			

ELECTRIC DEPARTMENT

UP-9

TYPICAL ROCK HOLE
INSTALLATION



GENERAL SPECIFICATIONS FOR INSTALLATION OF UNDERGROUND UTILITIES

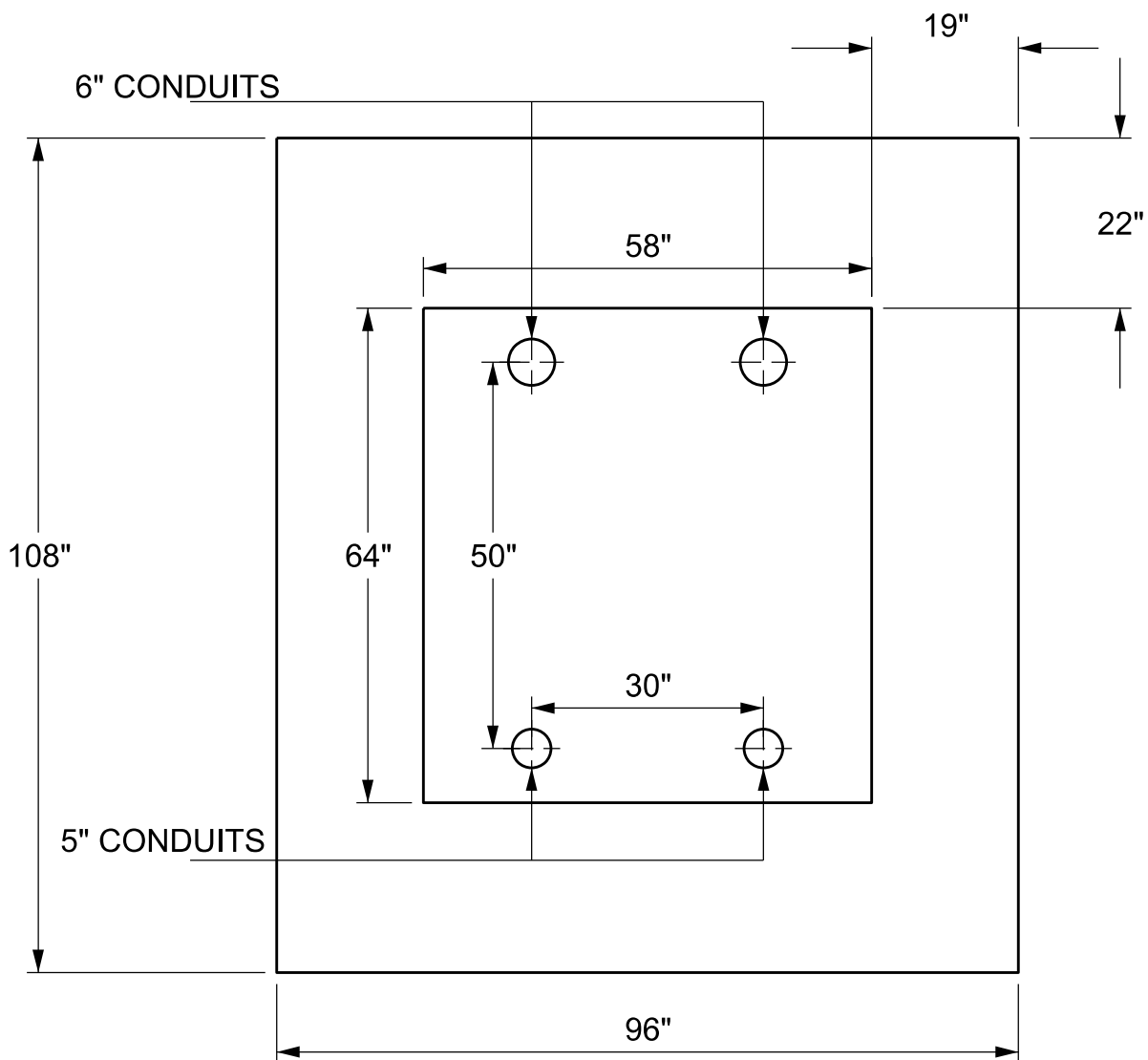

NOTES:

1. #4 REBAR
2. 2 MATS - 6" FROM TOP AND 6" FROM BOTTOM
3. PAD IS 24" THICK
4. INSPECTOR MUST SEE PAD BEFORE YOU POUR.

DWN J. BROWN	NO.	DATE	REVISION
DAT 09/04/13			
CKD			
DAT			
APP			
DAT			
APP			
DAT			
APP			
DAT			

ELECTRIC DEPARTMENT

UP-10

SWITCH GEAR CABINET



GENERAL SPECIFICATIONS FOR INSTALLATION OF UNDERGROUND UTILITIES